

The K/Series straight oil burner is a forced draft packaged burner system. A backward curved impeller mounted in a manufactured housing provides combustion air for various furnace pressures or high altitude applications. The KL oil burners incorporate a high pressure atomizing design using simplex or return flow nozzles. A directly driven fuel oil pump is burner mounted on sizes 13 through 42. A consistent fuel/air ratio is maintained regardless of firing rate.

The K/Series is listed by Underwriters Laboratory. CSD-1, Gap, F.M., NFPA-85 and other regulatory agency control options are available. Every burner is assembled, wired and tested at the factory.

### STANDARD EQUIPMENT

- ▶ 3450 RPM Blower Motor
- ▶ Panel Signal Lights: Power On, Main Fuel, Ignition, and Flame Failure
- ▶ Combustion Air Proving Switch
- ▶ Ignition Transformer
- ▶ 120/1/60 Control Circuit



### OPTIONAL FEATURES

S = STANDARD  
O = OPTIONAL  
N/A = NOT AVAILABLE

	KL-13				KL-54	KL-105
	KL-17			KL-34	KL-63	KL-125
	KL-21	KL-25	KL-30	KL-42	KL-84	KL-145
Flame Safeguard with U.V. Scanner	S	S	S	S	S	S
Low-High-Off Firing	S	S	S	S	N/A	N/A
Low-High-Low Firing	O	O	O	O	N/A	N/A
Full Modulation Firing	O	O	O	O	S	S
Directly Driven Oil Pump Set	S	S	S	S	N/A	N/A
Separately Driven Remote Oil Pump Set	O	O	O	O	S	S
Simplex Oil Nozzle	S	S	S	S	S	N/A
Return Flow Oil Nozzle	N/A	N/A	<sup>1</sup> O	<sup>1</sup> O	O	S

<sup>1</sup> Standard if Full Modulation is chosen.

# SPECIFICATIONS & DIMENSIONS

BURNER MODEL	FRAME SIZE	OIL INPUT (GPH)	FURN. PRESS. ("W.C.)	BHP @ 80% EFF.	MOTOR HP <sup>1</sup>	MOTOR HP <sup>2</sup>	REMOTE OIL PUMP MOTOR HP <sup>3</sup>	BLOWER MOTOR VOLT/ PH 60 HZ.
KL-13	1	8.9	0.75	30	1/2	1/2	1/3	115/1
KL-17	1	12.5	0.75	40	1/2	1/2	1/3	115/1
KL-21	1	14.9	0.75	50	3/4	3/4	1/3	115/1
KL-25	1	17.9	0.75	60	3/4	3/4	1/3	115/1
KL-30	2	20.9	1.5	70	3/4	3/4	1/3	115/1
KL-34	2	23.9	1.5	80	1	1	1/2	115/1
KL-42	2	29.9	1.5	100	2	2	1/2	208/230/460/3
KL-54	3	37.4	3.0	125	2	-	3/4	208/230/460/3
KL-63	3	44.8	3.0	150	3	-	3/4	208/230/460/3
KL-84	3	59.8	3.0	200	7 1/2	-	1	208/230/460/3
KL-105	4	74.7	4.0	250	5	-	1 1/2	208/230/460/3
KL-125	4	89.7	4.0	300	7 1/2	-	1 1/2	208/230/460/3
KL-145	4	105.0	4.0	350	10	-	1 1/2	208/230/460/3

- NOTES:**
- Gas input based on natural gas at 1,000 Btu/cu.ft. and 0.60 gravity.
  - Gas pressure based on zero furnace pressure. For total pressure at manifold, add furnace pressure.
  - Oil input based on No. 2 oil at 140,000 Btu/gal.
  - Boiler overall efficiency of 80% estimated.
  - Blower wheel and motor HP is based on altitude up to 2,000 ft. above sea level. For higher altitude or 50 Hz. applications, consult factory.
  - Firing at higher furnace pressures de-rates the burner by approximately 5% per 1/2" of additional pressure, consult factory.
- MOTOR SELECTIONS:**
- Motor ratings for gas only and remote oil pump burners.
  - Motor ratings for direct drive oil pump burners.
  - Remote oil pump is optional for all frame size 1-2. For frame size 3-4, a remote oil pump is standard.

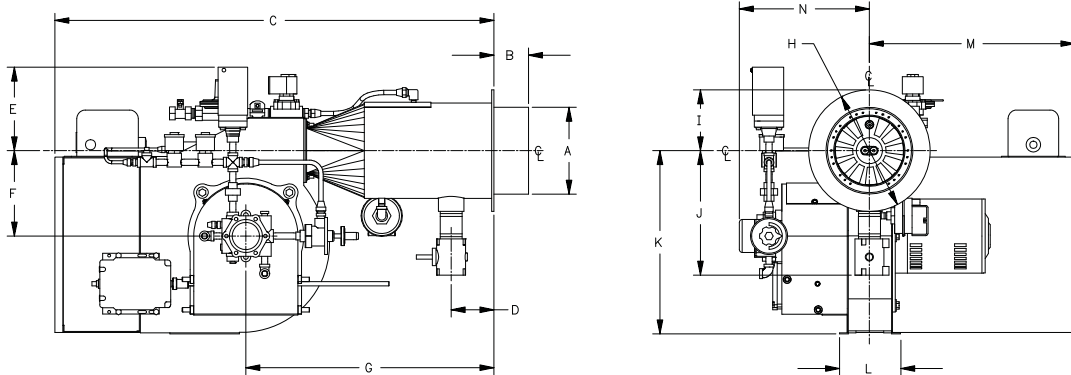

STANDARD CONFIGURATION

BURNER MODEL	A	B Std.	C	D	E	F	G	H	I	J	K	L	M	N
KL-13	7 1/2	3	37 7/8	3 5/8	7 1/4	7 3/8	21 3/8	10 1/2	5 1/4	10 3/4	15 7/8	5 1/4	18	11 1/4
KL-17	7 1/2	3	37 7/8	3 5/8	7 1/4	7 3/8	21 3/8	10 1/2	5 1/4	10 3/4	15 7/8	5 1/4	18	11 1/4
KL-21	7 1/2	3	37 7/8	3 5/8	7 1/4	7 3/8	21 3/8	10 1/2	5 1/4	10 3/4	15 7/8	5 1/4	18	11 1/4
KL-25	7 1/2	3	37 7/8	3 5/8	7 1/4	7 3/8	21 3/8	10 1/2	5 1/4	10 3/4	15 7/8	5 1/4	18	11 1/4
KL-30	9 1/4	4	41 7/8	4	7 1/8	8 7/8	23 3/8	12	6	11 3/8	19	6 1/2	17 3/8	12 7/8
KL-34	9 1/4	4	41 7/8	4	7 1/8	8 7/8	23 3/8	12	6	11 3/8	19	6 1/2	17 3/8	12 7/8
KL-42	9 1/4	4	41 7/8	4	7 1/8	8 7/8	23 3/8	12	6	11 3/8	19	6 1/2	17 3/8	12 7/8
KL-54	10 3/4	4	48 3/4	3 3/4	7 3/4	10 7/8	27 5/8	14 1/2	7 1/4	12 7/8	23 1/2	8	16 3/8	16 1/4
KL-63	10 3/4	4	48 3/4	3 3/4	7 3/4	10 7/8	27 5/8	14 1/2	7 1/4	12 7/8	23 1/2	8	16 3/8	16 1/4
KL-84	10 3/4	4	48 3/4	3 3/4	7 3/4	10 7/8	27 5/8	14 1/2	7 1/4	12 7/8	23 1/2	8	16 3/8	16 1/4
KL-105	12 1/8	5	56 3/8	3 7/8	8 3/4	12 1/2	32 7/8	17 1/2	8 3/4	15	27 1/8	10	17 3/8	20
KL-125	12 1/8	5	56 3/8	3 7/8	8 3/4	12 1/2	32 7/8	17 1/2	8 3/4	15	27 1/8	10	17 3/8	20
KL-145	12 1/8	5	56 3/8	3 7/8	8 3/4	12 1/2	32 7/8	17 1/2	8 3/4	15	27 1/8	10	17 3/8	20