

GENERAL DESCRIPTION

The M-Series gas, oil, and combination gas/oil burner is a forced draft packaged burner system. A backward curved aluminum impeller mounted in a machined housing provides combustion air for various furnace pressures or high altitude applications. The air housing is hinged for convenient inspection or service of the firing head components.

Oil firing features low pressure air atomizing design. A positive displacement oil metering unit, rotary vane air compressor, and air atomizing nozzle are integral parts of this system. The positive displacement oil metering unit is not affected by changes in oil temperature or viscosity.

Efficient gas combustion is attained by entering gas through ports ahead of the diffuser providing superior mixing of gas and air.

Excellent flame retention is assured at all firing rates. A gas manifold is provided on all oil burners for future addition of gas.

Combination gas/oil burners change from one fuel to the other by simply flipping a switch. No burner modifications or readjustments are required when changing from one fuel to the other.

The M-Series burners are built to the following standards; CSD-1, GE Gap, F.M., N.F.P.A., U.L., and other regulatory agencies where applicable.

Every burner is assembled, wired, and tested at the factory. Compressor modules and main gas train components are shipped loose.

U.L. STANDARD EQUIPMENT

A. CONTROLS

1. 120/1/60 control circuit
2. Burner mounted control panel
3. Motor starter(s)
4. Panel signal lights (4) (See Note 4)
5. Full Modulation with manual potentiometer (135 ohm)
6. Fuel changeover switch (combustion gas/oil models)
7. Flame safeguard controls (See Note 1)
8. Combustion air proving switch
9. High fire air interlock switch (M28-30)

B. OIL SYSTEM

1. Burner mounted air/oil metering system
2. Air/lube oil reservoir
3. Fuel oil strainer (burner)
4. 3-way oil solenoid valve
5. S.S.O. oil solenoid valve with relief valve
6. Atomizing air interlock switch
7. Nozzle line heater w/cold oil lockout

C. MAIN GAS SYSTEM (See Note 1)

1. Butterfly rate control valve
2. One motorized valve and solenoid valve
3. Gas shutoff cocks (2)
4. Main gas regulator
5. High and low gas pressure switches (M28-30)

D. IGNITION SYSTEM

1. Direct spark ignition (MM14-30)
2. Gas-electric interrupted pilot (MG-MMG-ME-MEG)
3. Shutoff cock
4. Separate pilot regulator and valve

E. OTHER EQUIPMENT

1. 3450 rpm blower motor and aluminum impeller
2. Burner mounting flange
3. Refractory combustion cone and gasket
4. Hinged, swing-away air housing
5. Gas manifold is standard on all oil burners for future gas firing

F. OPTIONAL EQUIPMENT

1. Cam trim UL listed
2. Control circuit transformer

NOTES

1. Lead sulphide scanner standard U.V. optional.
2. All main gas line valves and accessories upstream of butterfly valve are shipped loose.
3. Standard motor voltages are 208-230-460/3/60
Totally enclosed and 50 cycle motors are optional.
4. Signal lights:
Power On, Main Fuel, Ignition, and Flame Failure
5. A separate oil circulating pump set is required for all oil and combination fuel burners. The burner mounted unit is an oil input metering device only.

ORDERING INFORMATION (SPECIFY)

1. Blower motor voltage, phase and cycle (See Note 3)
2. Control circuit voltage (120/1/60 is standard)
3. Burner model and actual firing rate
4. Flame safeguard control
5. Special Code and/or Insurance Requirements
6. Available Gas Pressure

Type of fuel determines the model designation	
Model	Fuel
MG	Gas
MM	No. 2-5 Oil
MMG	No. 2-5 Oil / Gas
ME	No. 2-6 Oil
MEG	No. 2-6 Oil / Gas

CAPACITIES & SPECIFICATIONS	BURNER SIZE			
	14	16	19	22
GAS INPUT (Mbtu/hr) (See Note 1)	1,400	1,680	1,960	2,200
OIL INPUT (U.S. GPH) (See Note 2)	10	12	14	15.7
BOILER HP @ 80% EFF. (See Note 3)	33	40	47	52
GAS MANIFOLD PRESS. ("w.c.) (See Note 4)	2	2.5	3	3
BLOWER MOTOR HP (Gas only or w/remote oil pump)(See Note 5)	1/2	1/2	1/2	1/2
OIL METERING UNIT MOTOR HP (ME-MEG)	1/2	1/2	1/2	1/2
AIR COMPRESSOR MOTOR HP (ME-MEG)	3	3	3	3
INTEGRAL AIR/OIL UNIT MOTOR HP (MM-MMG)	3/4	3/4	3/4	3/4
NOZZLE LINE HEATER (KW) (MM-MMG-ME-MEG)	3	3	3	3
APPROX. SHIPPING WEIGHT (LBS)	450	450	450	450

CAPACITIES & SPECIFICATIONS	BURNER SIZE		
	25	28	30
GAS INPUT (Mbtu/hr) (See Note 1)	2,490	2,800	3,150
OIL INPUT (U.S. GPH) (See Note 2)	18	20	22.5
BOILER HP @ 80% EFF. (See Note 3)	59	67	75
GAS MANIFOLD PRESS. ("w.c.) (See Note 4)	3	3	3.5
BLOWER MOTOR HP (Gas only or w/remote oil pump)(See Note 5)	2	2	2
OIL METERING UNIT MOTOR HP (ME-MEG)	1/2	1/2	1/2
AIR COMPRESSOR MOTOR HP (ME-MEG)	3	3	3
INTEGRAL AIR/OIL UNIT MOTOR HP (MM-MMG)	3/4	3/4	3/4
NOZZLE LINE HEATER (KW) (MM-MMG-ME-MEG)	3	3	3
APPROX. SHIPPING WEIGHT (LBS)	500	500	500

Notes:

1. Gas input based on natural gas at 1,000 Btu/cu.ft. and 0.60 gravity
2. Oil input based on No. 2 oil at 140,000 Btu/gal.
3. Boiler overall efficiency of 80% estimated
4. Gas pressure based on zero furnace pressure. For total pressure at manifold, add furnace pressure.
5. Impeller and motor HP is based on altitude up to 2,000 ft. above sea level, and up to 1.5" WC furnace pressure. For higher altitude or 50 Hz applications, consult factory.
Standard motor voltages are 208-230-460/3/60

GENERAL DIMENSIONS

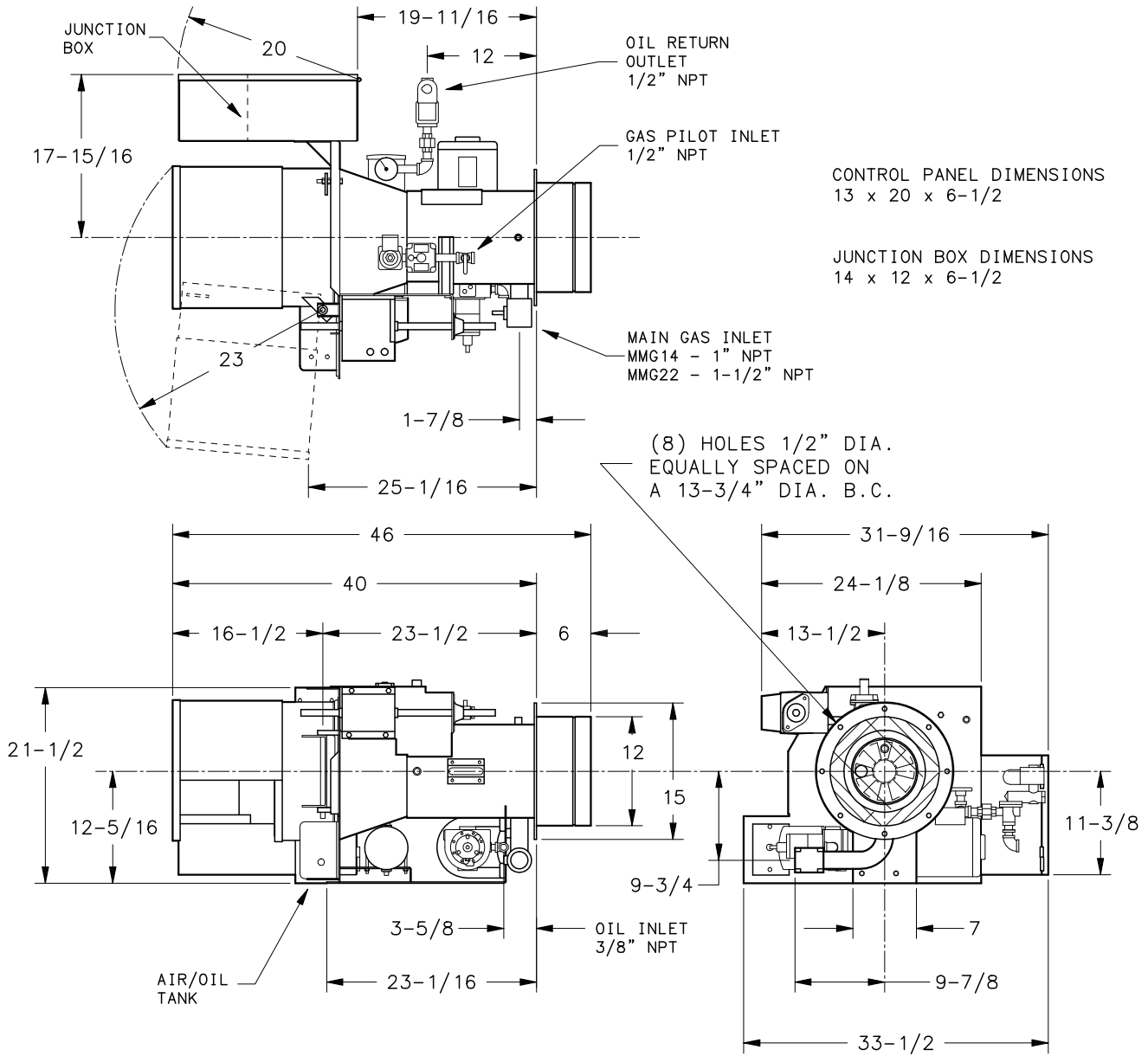

NOTE:
THESE DIMENSIONS ARE FOR REFERENCE ONLY. SPECIFICATIONS
AND DIMENSIONS ARE SUBJECT TO CHANGE WITHOUT NOTICE.
OBTAIN A CERTIFIED PRINT FROM THE FACTORY BEFORE INSTALLATION.

DIMENSION DIAGRAM
M-MODEL MMG 14-22
H0-06379-01

GENERAL DIMENSIONS

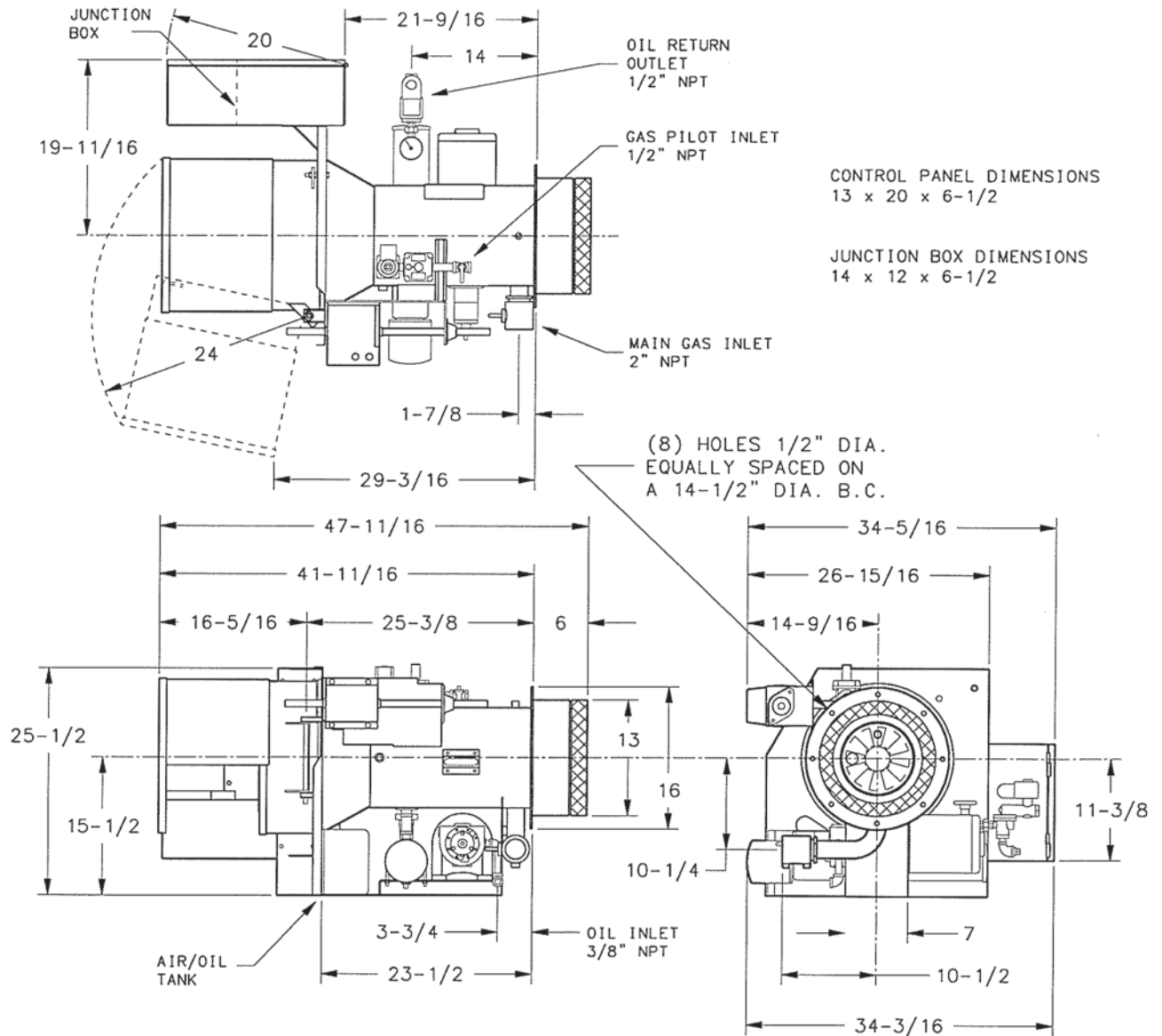

NOTE:
THESE DIMENSIONS ARE FOR REFERENCE ONLY. SPECIFICATIONS
AND DIMENSIONS ARE SUBJECT TO CHANGE WITHOUT NOTICE.
OBTAIN A CERTIFIED PRINT FROM THE FACTORY BEFORE INSTALLATION.

DIMENSION DIAGRAM
M-MODEL MMG 25-30
552-00030-00

GENERAL DESCRIPTION

The M/Series gas, oil, and combination gas/oil burner is a forced draft packaged burner system. A backward curved aluminum impeller mounted in a machined housing provides combustion air for various furnace pressures or high altitude applications. The air housing is hinged for convenient inspection or service of the firing head components.

Oil firing features low pressure air atomizing design. A positive displacement oil metering unit, rotary vane air compressor, and air atomizing nozzle are integral parts of this system. The positive displacement oil metering unit is not affected by changes in oil temperature or viscosity.

Efficient gas combustion is attained by entering gas through ports ahead of the diffuser providing superior mixing of gas and air.

Excellent flame retention is assured at all firing rates. A gas manifold is provided on all oil burners for future addition of gas.

Combination gas/oil burners change from one fuel to the other by simply flipping a switch. No burner modifications or readjustments are required when changing from one fuel to the other.

The M/Series burners are built to the following standards; CSD-1, GE Gap, F.M., N.F.P.A., U.L., and other regulatory agencies where applicable.

Every burner is assembled, wired, and tested at the factory. Compressor modules and main gas train components are shipped loose.

U.L. STANDARD EQUIPMENT

A. CONTROLS

1. 120/1/60 control circuit
2. Burner mounted control panel
3. Motor starter(s)
4. Panel signal lights (4) (See Note 4)
5. Full Modulation with manual potentiometer (135 ohm)
6. Fuel changeover switch (combustion gas/oil models)
7. Flame safeguard controls (See Note 1)
8. Combustion air proving switch
9. High fire air interlock switch

B. OIL SYSTEM

1. Burner mounted air/oil metering system (MM-MMG)
2. Burner mounted oil metering system (ME-MEG)
3. Separate air compressor module (ME-MEG)
4. Air/lube oil reservoir
5. Fuel oil strainer (burner)
6. 3-way oil solenoid valve
7. S.S.O. oil solenoid valve with relief valve
8. High oil temp switch mounted (loose)
9. Low oil pressure switch (ME-MEG)
10. Atomizing air interlock switch
11. Nozzle line heater w/cold oil lockout

C. MAIN GAS SYSTEM (See Note 1)

1. Butterfly rate control valve
2. One motorized valve and solenoid valve (M34-42)
3. One motorized valve with closure interlock and one solenoid valve motorized (M54-63)
4. Gas shutoff cocks (2)
5. Main gas regulator
6. High and low gas pressure switches

D. IGNITION SYSTEM

1. Direct spark ignition (MM)
2. Gas-electric interrupted pilot (MG-MMG-ME-MEG)
3. Shutoff cock
4. Separate pilot regulator and valve

E. OTHER EQUIPMENT

1. 3450 rpm blower motor and aluminum impeller
2. Burner mounting flange
3. Refractory combustion cone and gasket
4. Hinged, swing-away air housing
5. Air damper w/silencer
6. Bolt on firing head
7. Gas manifold is standard on all oil burners for future gas firing
8. Cam Trim U.L. listed (MM-MMG-ME-MEG)

F. OPTIONAL EQUIPMENT

1. Cam trim UL listed (MG)
2. Control circuit transformer

NOTES

1. Lead sulphide scanner standard U.V. optional.
2. All main gas line valves and accessories upstream of butterfly valve are shipped loose.
3. Standard motor voltages are 208-230-460/3/60
Totally enclosed and 50 cycle motors are optional.
4. Signal lights:
Power On, Main Fuel, Ignition, and Flame Failure
5. A separate oil circulating pump set is required for all oil and combination fuel burners. The burner mounted unit is an oil input metering device only.

ORDERING INFORMATION (SPECIFY)**Product Information**

1. Blower motor voltage, phase and cycle (See Note 3)
2. Control circuit voltage (120/1/60 is standard)
3. Burner model and actual firing rate
4. Flame safeguard control
5. Special Code and/or Insurance Requirements
6. Available Gas Pressure

Type of fuel determines the model designation	
Model	Fuel
MG	Gas
MM	No. 2-5 Oil
MMG	No. 2-5 Oil / Gas
ME	No. 2-6 Oil
MEG	No. 2-6 Oil / Gas

CAPACITIES & SPECIFICATIONS	BURNER SIZE			
	34	42	54	63
GAS INPUT (Mbtu/hr) (See Note 1)	3,500	4,200	5,600	6,300
OIL INPUT (U.S. GPH) (See Note 2)	25	31	40	45
BOILER HP @ 80% EFF. (See Note 3)	83	100	133	150
GAS MANIFOLD PRESS. ("w.c.) (See Note 4)	4	4	4	5
BLOWER MOTOR HP - S Model (See Note 5)	2	2	2	3
BLOWER MOTOR HP - P Model (See Note 5)	2	2	3	3
OIL METERING UNIT MOTOR HP (ME-MEG)	1/2	1/2	1/2	1/2
AIR COMPRESSOR MOTOR HP (ME-MEG)	3	3	3	3
INTEGRAL AIR/OIL UNIT MOTOR HP (MM-MMG)	1	1	1	1
NOZZLE LINE HEATER (KW) (MM-MMG-ME-MEG)	3	3	3	3
APPROX. SHIPPING WEIGHT (LBS)	650	650	750	750

Notes:

1. Gas input based on natural gas at 1,000 Btu/cu.ft. and 0.60 gravity
2. Oil input based on No. 2 oil at 140,000 Btu/gal.
3. Boiler overall efficiency of 80% estimated
4. Gas pressure based on zero furnace pressure. For total pressure at manifold, add furnace pressure.
5. Impeller and motor HP is based on altitude up to 2,000 ft. above sea level.
For higher altitude or 50 Hz applications, consult factory.
Use model "S" up to 0.75" w.c. furnace pressure
Use model "P" up to 2" w.c. furnace pressure
Standard motor voltages are 208-230-460/3/60

GENERAL DIMENSIONS

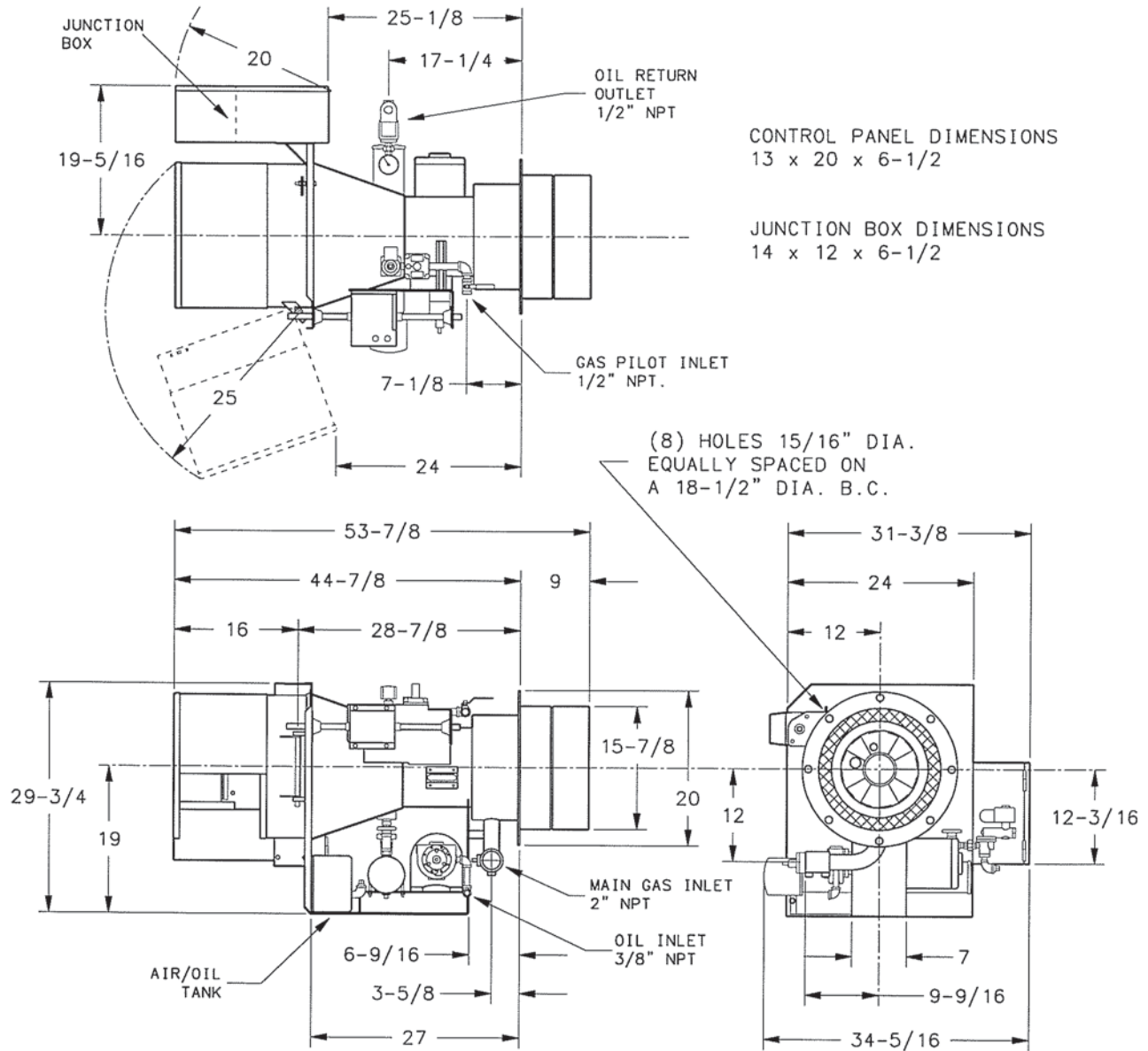

NOTE:
THESE DIMENSIONS ARE FOR REFERENCE ONLY. SPECIFICATIONS
AND DIMENSIONS ARE SUBJECT TO CHANGE WITHOUT NOTICE.
OBTAIN A CERTIFIED PRINT FROM THE FACTORY BEFORE INSTALLATION.

DIMENSION DIAGRAM
M-MODEL MMG 34-63
552-00015-00

GENERAL DIMENSIONS

CONTROL PANEL DIMENSIONS
23-1/2 x 19-1/2 x 7-1/4

JUNCTION BOX DIMENSIONS
14 x 12 x 6-1/2

SEPARATE COMPRESSOR DIMENSIONS

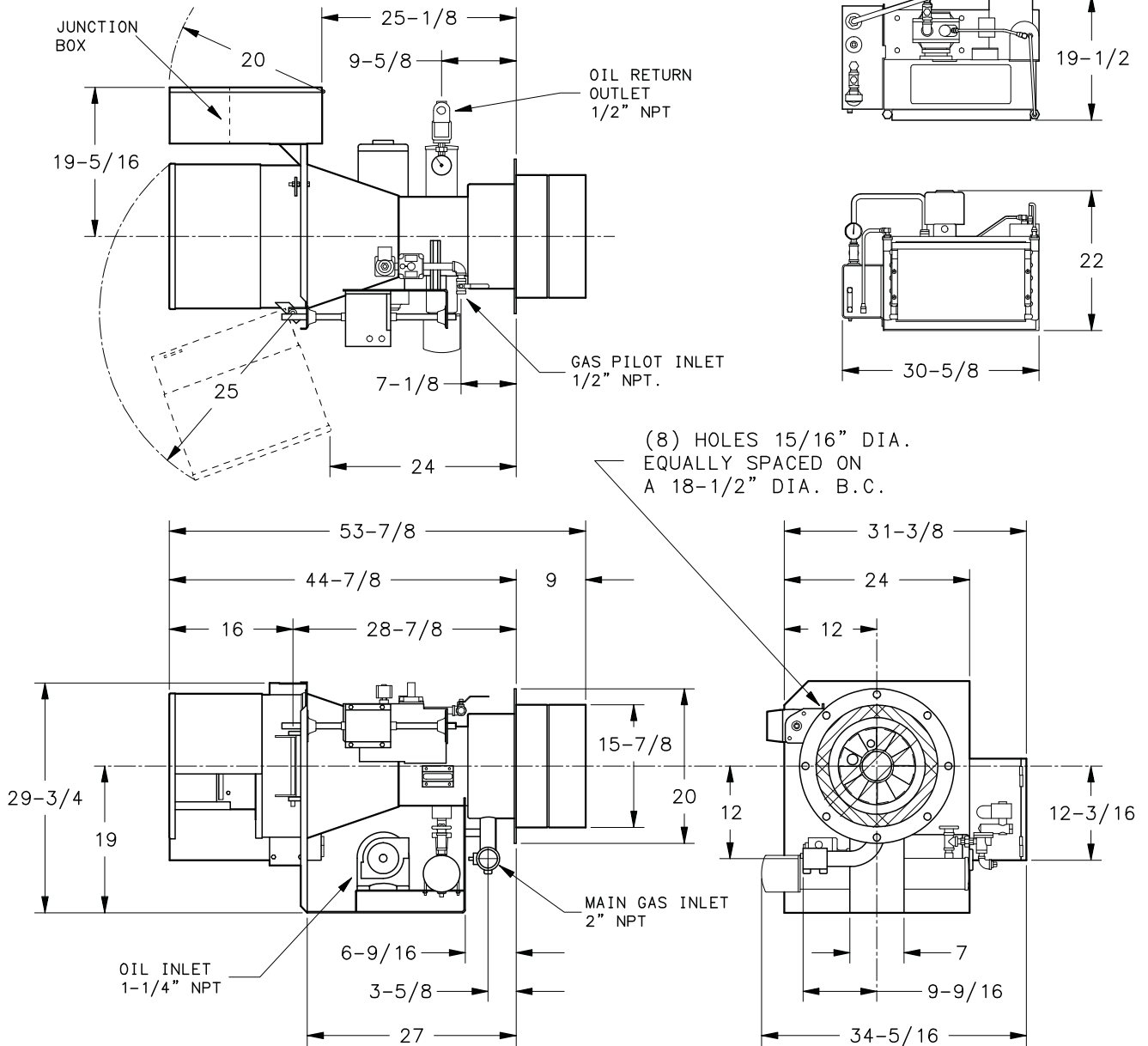

NOTE:
THESE DIMENSIONS ARE FOR REFERENCE ONLY. SPECIFICATIONS
AND DIMENSIONS ARE SUBJECT TO CHANGE WITHOUT NOTICE.
OBTAIN A CERTIFIED PRINT FROM THE FACTORY BEFORE INSTALLATION.

DIMENSION DIAGRAM
M-MODEL MEG-34-62
H0-06377-01

GENERAL DESCRIPTION

The M-Series gas, oil, and combination gas/oil burner is a forced draft packaged burner system. A backward curved aluminum impeller mounted in a machined housing provides combustion air for various furnace pressures or high altitude applications. The air housing is hinged for convenient inspection or service of the firing head components.

Oil firing features low pressure air atomizing design. A positive displacement oil metering unit, rotary vane air compressor, and air atomizing nozzle are integral parts of this system. The positive displacement oil metering unit is not affected by changes in oil temperature or viscosity.

Efficient gas combustion is attained by entering gas through ports ahead of the diffuser providing superior mixing of gas and air.

Excellent flame retention is assured at all firing rates. A gas manifold is provided on all oil burners for future addition of gas.

Combination gas/oil burners change from one fuel to the other by simply flipping a switch. No burner modifications or readjustments are required when changing from one fuel to the other.

The M-Series burners are built to the following standards; CSD-1, GE Gap, F.M., N.F.P.A., U.L., and other regulatory agencies where applicable.

Every burner is assembled, wired, and tested at the factory. Compressor modules and main gas train components are shipped loose.

U.L. STANDARD EQUIPMENT

A. CONTROLS

1. 120/1/60 control circuit
2. Burner mounted control panel
3. Motor starter(s)
4. Panel signal lights (4) (See Note 4)
5. Full Modulation with manual potentiometer (135 ohm)
6. Fuel changeover switch (combustion gas/oil models)
7. Flame safeguard controls (See Note 1)
8. Combustion air proving switch
9. High fire air interlock switch

B. OIL SYSTEM

1. Burner mounted air/oil metering system (MM-MMG)
2. Burner mounted oil metering system (ME-MEG)
3. Separate air compressor module (ME-MEG)
4. Air/lube oil reservoir
5. Fuel oil strainer (burner)
6. 3-way oil solenoid valve
7. S.S.O. oil solenoid valve with relief valve
8. High oil temp switch mounted (loose)
9. Low oil pressure switch (ME-MEG)
10. Atomizing air interlock switch
11. Nozzle line heater w/cold oil lockout (MM-MMG-ME-MEG)

C. MAIN GAS SYSTEM (See Note 1)

1. Butterfly rate control valve
2. One motorized valve with closure interlock and one solenoid valve motorized
3. Gas shutoff cocks (2)
4. Main gas regulator
5. High and low gas pressure switches

D. IGNITION SYSTEM

1. Gas-electric interrupted pilot
2. Shutoff cock
3. Separate pilot regulator and valve

E. OTHER EQUIPMENT

1. 3450 rpm blower motor and aluminum impeller
2. Burner mounting flange
3. Refractory combustion cone and gasket
4. Hinged, swing-away air housing
5. Air damper w/silencer
6. Bolt on firing head
7. Gas manifold is standard on all oil burners for future gas firing
8. Cam Trim U.L. listed (MM-MMG)

F. OPTIONAL EQUIPMENT

1. Cam trim UL listed (MG)
2. Control circuit transformer

NOTES

1. Lead sulphide scanner standard U.V. optional.
2. All main gas line valves and accessories upstream of butterfly valve are shipped loose.
3. Standard motor voltages are 208-230-460/3/60
Totally enclosed and 50 cycle motors are optional.
4. Signal lights:
Power On, Main Fuel, Ignition, and Flame Failure
5. A separate oil circulating pump set is required for all oil and combination fuel burners. The burner mounted unit is an oil input metering device only.

ORDERING INFORMATION (SPECIFY)

Product Information

1. Blower motor voltage, phase and cycle (See Note 3)
2. Control circuit voltage (120/1/60 is standard)
3. Burner model and actual firing rate
4. Flame safeguard control
5. Special Code and/or Insurance Requirements
6. Available Gas Pressure

Type of fuel determines the model designation	
Model	Fuel
MG	Gas
MM	No. 2-5 Oil
MMG	No. 2-5 Oil / Gas
ME	No. 2-6 Oil
MEG	No. 2-6 Oil / Gas

CAPACITIES & SPECIFICATIONS	BURNER SIZE	
	84	105
GAS INPUT (Mbtu/hr) (See Note 1)	8,400	10,500
OIL INPUT (U.S. GPH) (See Note 2)	60	75
BOILER HP @ 80% EFF. (See Note 3)	200	250
GAS MANIFOLD PRESS. ("w.c.) (See Note 4)	4	4
BLOWER MOTOR HP - S Model (See Note 5)	5	7.5
BLOWER MOTOR HP - P Model (See Note 5)	7.5	7.5
OIL METERING UNIT MOTOR HP (ME-MEG)	1/2	1/2
AIR COMPRESSOR MOTOR HP (ME-MEG)	3	3
INTEGRAL AIR/OIL UNIT MOTOR HP (MM-MMG)	2	2
NOZZLE LINE HEATER (KW) (MM-MMG-ME-MEG)	5	5
APPROX. SHIPPING WEIGHT (LBS)	1,200	1,250

Notes:

1. Gas input based on natural gas at 1,000 Btu/cu.ft. and 0.60 gravity
2. Oil input based on No. 2 oil at 140,000 Btu/gal.
3. Boiler overall efficiency of 80% estimated
4. Gas pressure based on zero furnace pressure. For total pressure at manifold, add furnace pressure.
5. Impeller and motor HP is based on altitude up to 2,000 ft. above sea level.
For higher altitude or 50 Hz applications, consult factory.
Use model "S" up to 0.75" w.c. furnace pressure
Use model "P" up to 2" w.c. furnace pressure
Standard motor voltages are 208-230-460/3/60

GENERAL DIMENSIONS

CONTROL PANEL DIMENSIONS
23-1/2 x 19-1/2 x 7-1/4

JUNCTION BOX DIMENSIONS
14 x 12 x 6-1/2

SEPARATE COMPRESSOR
DIMENSIONS

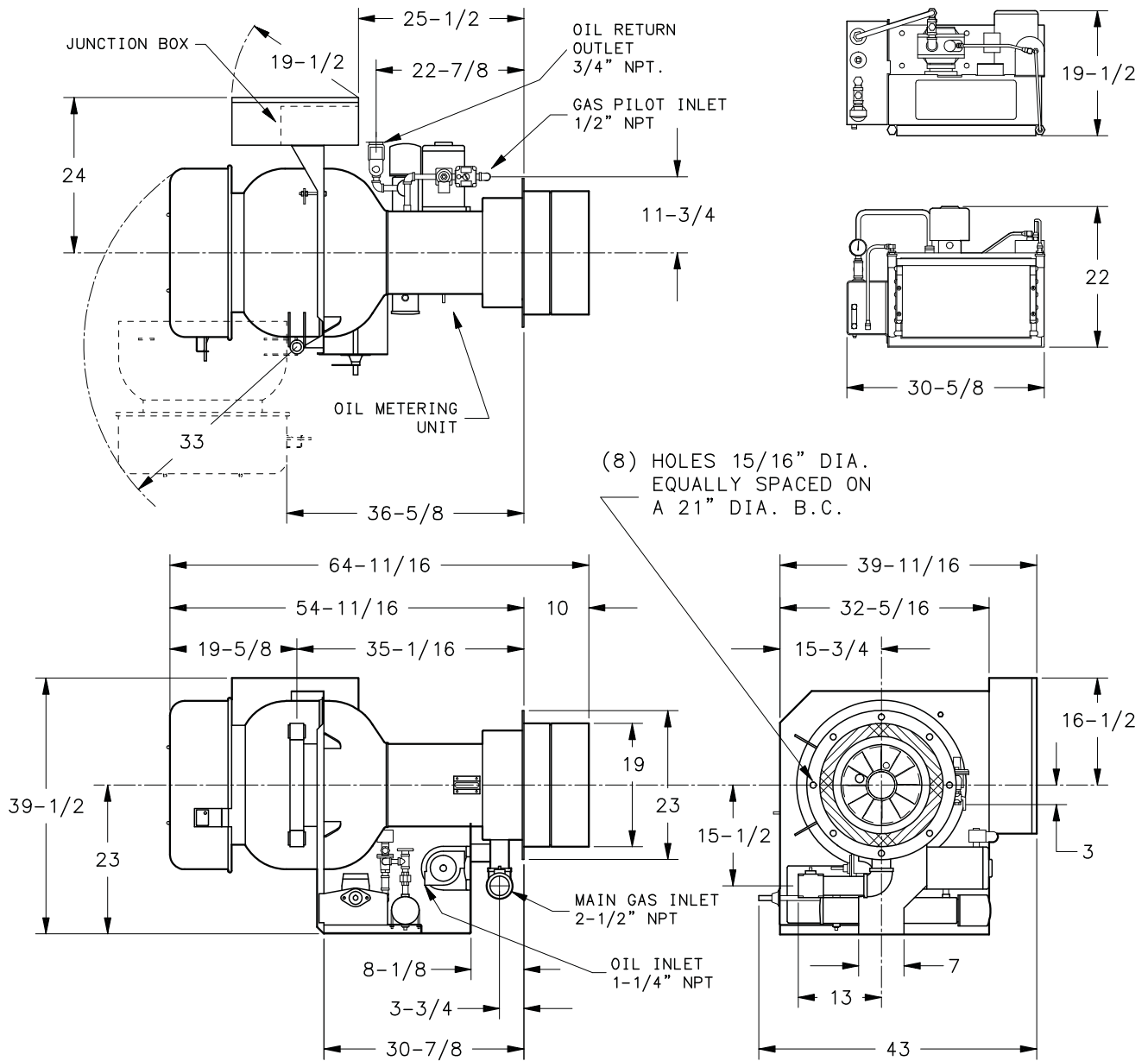

NOTE:
THESE DIMENSIONS ARE FOR REFERENCE ONLY. SPECIFICATIONS AND DIMENSIONS ARE SUBJECT TO CHANGE WITHOUT NOTICE. OBTAIN A CERTIFIED PRINT FROM THE FACTORY BEFORE INSTALLATION.

DIMENSION DIAGRAM
M-MODEL MMG 84-105
H0-06346-02